

SERIES I -1540 9ft Transverse Crane Body

Flat Top Cabinets

Body Materials

- 14 ga A60 galvalume cabinet panels
- 12 ga A60 galvalume single panel doors
- 2" x 2" x 1/4" wall tube long sills run full length
- 12 ga 2x4 formed C channel cross rails
- 14 ga A60 galvalume treadplate deck floor
- 11ga treadplate step/bumper

Body Dimensions

- 79.5" Max Cabinet width, 82" Overall Body Width @ drip rails
- 15" Overall cabinet depth with 13.88" inside depth clearance
- 40" Overall cabinet height
- 49.5" x 71" Deck Area
- 21" Deck Side Height
- 8.5" Treadplate step and integrated vise mount

Standard Features

- Body, crane tower, and outriggers rated at 10,000 ft-lbs moment load
- 75.5 Cubic feet of storage capacity
- Stainless Steel wrap around chip guard full height on front of cabinets
- Full length rain gutter
- Galvanized infinitely adjustable shelving (6 shelf kit) 250 lb capacity
- Fully sealed crane tower also functions as a storage cabinet
- 3 point locking door system features blind mounted door handles for security
- Polished stainless steel door handles feature compression latching, paddle lockable
- (4) Flush mounted cargo tie downs
- Stainless Steel spring loaded door checks
- Body mounted back-up alarm
- Automotive bulb, steelbacked weather stripping between doors and cabinets
- Plug and Play harnessing
- Body is fully sanded, chemically washed and prepped prior to paint
- 3 step Paint Process with PPG Delfleet Polyurethane topcoat - exterior and interior
- Body is fully undercoated
- LED Lights and reflectors are mounted per DOT specifications
- Internal Hinge Design
- Standard mounting points for Air Compressor
- Mud Flaps

Options

- Rollout Drawers and Bolt bins
- Welders
- Cabinet Strip Lighting
- Bedliner
- Deck Covers
- Lube Kits
- Gas Compressors
- LED Exterior Lighting
- Tailgate
- Trailer Plug
- Inverters
- High performance cabinet pressurization system with filtered air

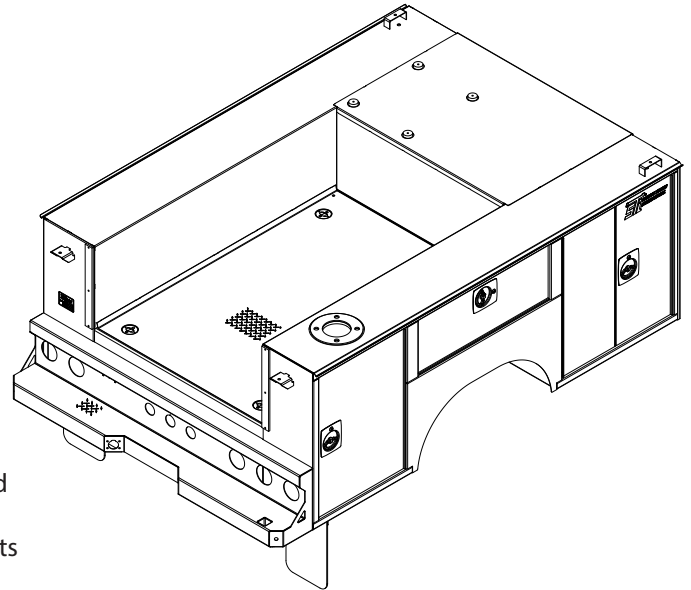

SERIES I - 1540 9ft Transverse Crane Body Dimensions

