



TIGER

CRANES

Model 6541E Specifications

Model 6541E Specifications

Dimensional Specifications:

- 21' Reach
- 12-21' Hydraulic Boom Extension
- 18.5' Lifting Height
- 37" Storage Height
- 159" Overall Storage Length
- Ø18" Mounting Space Required
- 6 Bolt Mounting Pattern
- 3/8" X 120' Winch Cable
- 1565 lbs. Operating Weight
- Ø38.25" Rotation Clearance Required

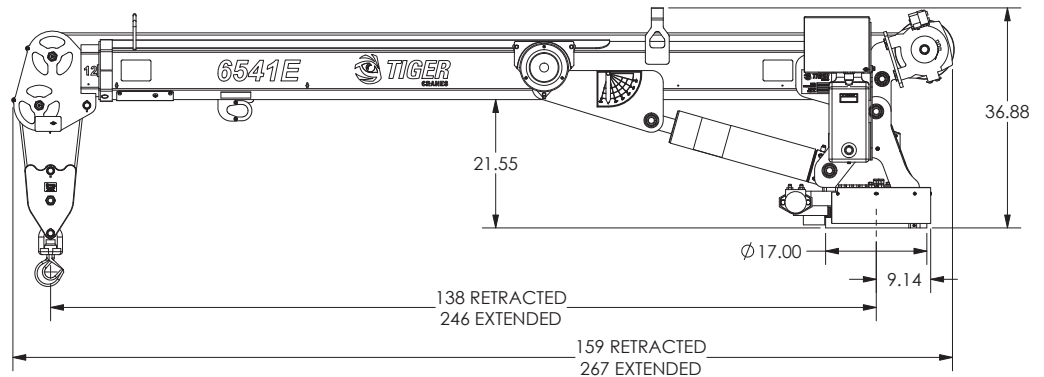

Performance Specifications:

- 40,000 ft-lb Crane Rating
- 47,300 ft-lb Maximum Crane Lifting Moment
- 6,500 lb Double Line Lift Capacity
- 400 Degrees of Rotation
- -8 Degrees to +81 Degrees Boom Angle
- Winch Performance

LOAD	PART LINE	LIFTING SPEED
0 lbs	1	36 FPM
3250 lbs	2	10 FPM

Standard Features:

- 25' tethered control included for operation
- Anti two block & overload protection with lighted indication
- 10 VDC Cartridge Valves with manual overrides
- Electric planetary winch. Boom mounted for easier stowing.
- Sealed turret
- Crane lift and extension cylinders are equipped with counterbalance safety valves.
- Powder coated base, turret shield and inner boom, with PPG Delfleet polyurethane paint on other components.
- This crane is designed to meet the requirements of ANSI/ASME B30.5 (2011) and OSHA 1910.180.

Optional Features:

Available on model 6541EP

- Proportional Wireless Control with 2 way remote to receiver communication, including 3 hydraulic functions with proportional trigger, 1 on/off winch function with trigger interlock, horn button, engine start/stop switch and engine speed control and accessory switch. Requires 4 AA batteries.
- Load percentage indication with 4 character display on remote.
- 33' tether cable included for operation without batteries or in areas where radio transmission is not allowed.

Minimum Chassis/Power Requirements:

- 14,500 lbs. GVW Rating
- 60" Cab to Axle
- 300,000 in-lb frame RBM
- 40,000 ft-lb Rated Outrigger
- 90 Amp Alternator
- 700 Cold Cranking Amp Battery



TIGER

CRANES

Model 6541E Specifications

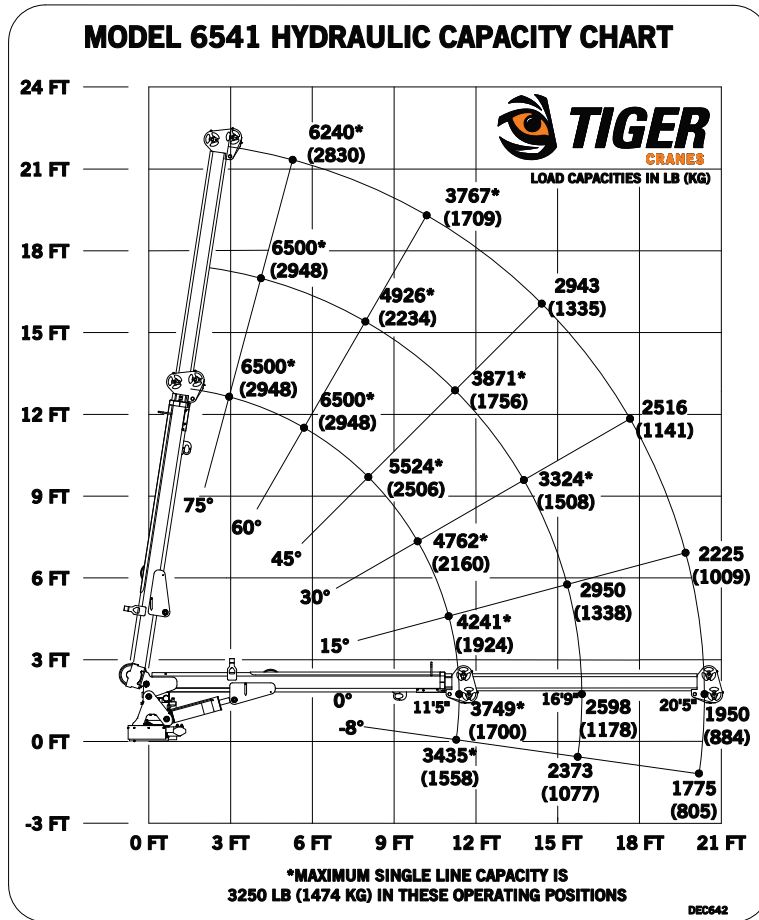

Bolt Hole Pattern

