



TIGER

CRANES

Model 5032EP Specifications

Model 5032EP Specifications

Dimensional Specifications:

- 21' Reach
- 12-21' Hydraulic boom extension
- 18.5' Lifting height
- 39" Storage height
- 161" Overall storage length
- Ø18" Mounting space required
- 6 Bolt mounting pattern
- 3/8" X 120' hoist cable
- 1445 lbs. Operating weight
- Ø29" Rotation clearance required

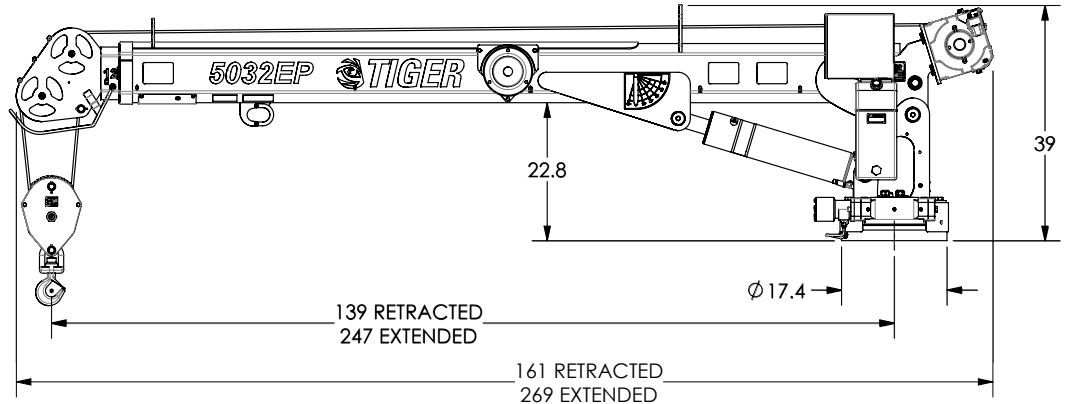

Performance Specifications:

- 30,000 ft-lb Crane rating
- 32,975 ft-lb Maximum crane lifting moment
- 5,000 lb Double line lift capacity
- 400 Degrees of rotation
- -15 Degrees to +73 degrees boom angle
- Hoist performance

LINE LOAD	LINE SPEED
0 lbs	23 FPM
1250 lbs	18 FPM
2500 lbs	16 FPM

Standard Features:

- Wireless pistol grip control with high resolution LCD display for load percentage and diagnostics. Dual joysticks for selecting hydraulic/electric functions with proportional control trigger. Also includes horn, boom lights, compressor, engine start/stop, engine speed control, and 2 auxiliary switches.
- 33' tether cable included for operation without batteries or in areas where radio transmission is not allowed
- Low profile anti-two-block protection
- Overload protection
- 10 VDC cartridge valves with manual overrides
- Boom mounted electric planetary hoist for easier stowing
- Stationary rotator gearcase
- Sealed crane turret
- Low profile jib head
- Hydraulic cylinders equipped with counterbalance safety valves
- PPG Delfleet polyurethane paint
- Designed to meet the requirements of ANSI/ASME B30.5 (2018) and OSHA 1910.180.

Optional Features:

- Self-leveling LED boom tip lights controlled by remote

Minimum Chassis/Power Requirements:

- 14,500 lbs. GVW rating
- 60" Cab to axle
- 300,000 in-lb frame RBM
- 30,000 ft-lb rated outrigger
- 200 Amp alternator
- 700 Cold cranking amp battery



TIGER

CRANES

Model 5032EP Specifications

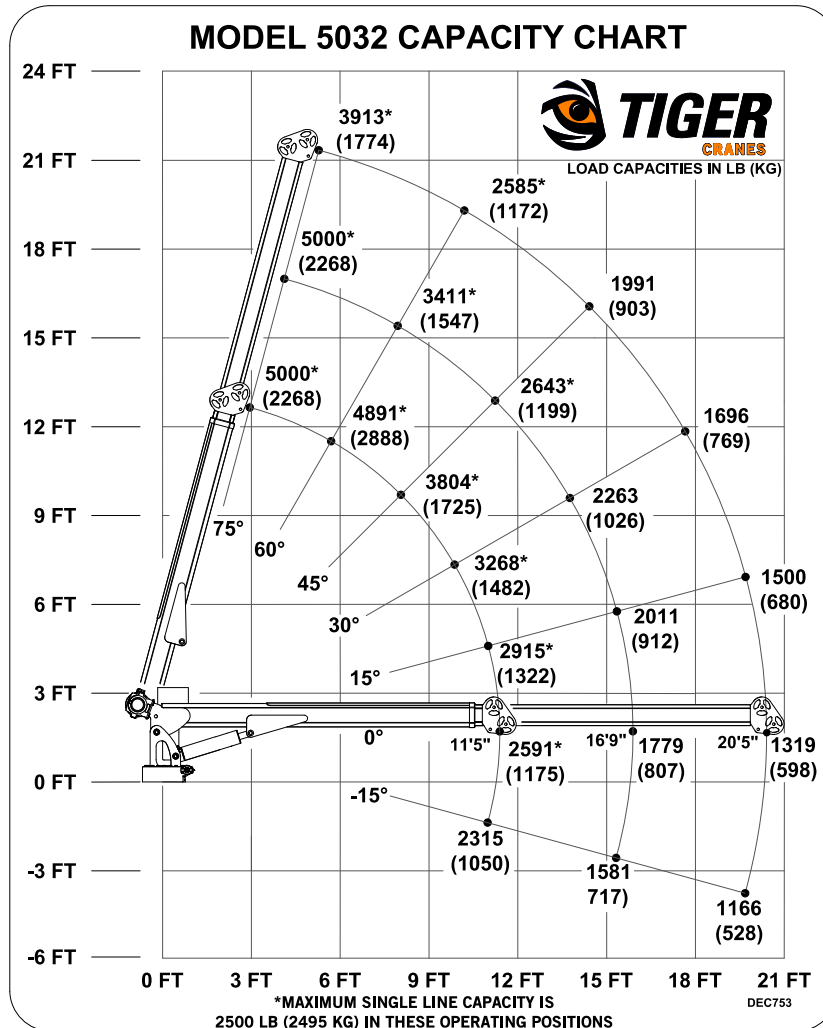

Bolt Hole Pattern

