



# TIGER

## CRANES

### Model 6542 Specifications

#### Model 6542 Specifications

##### Dimensional Specifications:

- 21' Reach
- 12-21' Hydraulic boom extension
- 18.5' Lifting height
- 39.5" Storage height
- 161" Overall storage length
- Ø18" Mounting space required
- 6 Bolt mounting pattern
- 3/8" X 120' Winch cable
- 1450 lbs. Operating weight
- Ø27" Rotation clearance required

##### Performance Specifications:

- 40,000 ft-lb Crane rating
- 43,200 ft-lb Maximum crane lifting moment
- 6,500 lb Double line lift capacity
- 11 Second boom elevation time
- 16 Second boom extension time
- 1.3 RPM Rotation speed
- 70 FPM No load single line speed
- 400 Degrees of rotation
- -15 Degrees to +73 degrees boom angle

##### Standard Features:

- Wireless pistol grip control with high resolution LCD display for load percentage and diagnostics. Dual joysticks for selecting hydraulic functions with proportional control trigger. Also includes horn, boom lights, compressor, engine start/stop, engine speed control, and 3 auxiliary switches.
- 33' tether cable included for operation without batteries or in areas where radio transmission is not allowed
- Low profile anti-two-block protection
- Overload protection
- Stationary rotator gearcase
- Sealed crane turret
- Low profile jib head
- Integrated filtration with bypass condition indicator
- 12 VDC DO3 10 GPM solenoids with manual overrides & LED On/Off indicator DIN connectors
- Boom mounted hydraulic planetary winch for easier stowing
- Hydraulic cylinders equipped with counterbalance safety valves
- PPG Delfleet polyurethane paint
- Designed to meet the requirements of ANSI/ASME B30.5 (2014) and OSHA 1910.180.

##### Optional Features:

- Self-leveling LED boom tip lights controlled by remote

##### Minimum Requirements:

- 14,500 lbs. GVW rating
- 60" Cab to axle
- 300,000 in-lb frame RBM
- 8 GPM @ 2750 PSI – open center hydraulics
- 40,000 ft-lb rated crane tower reinforcement and outrigger

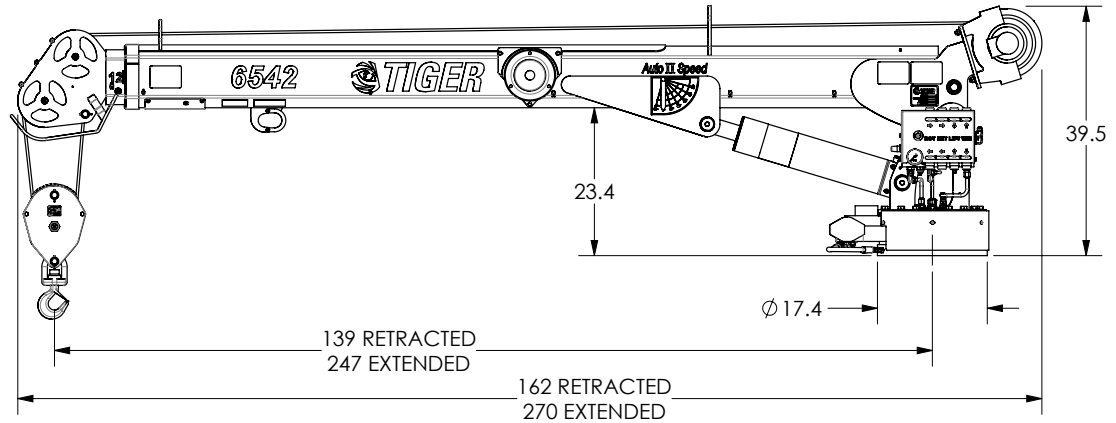



# TIGER

## CRANES

### Model 6542 Specifications

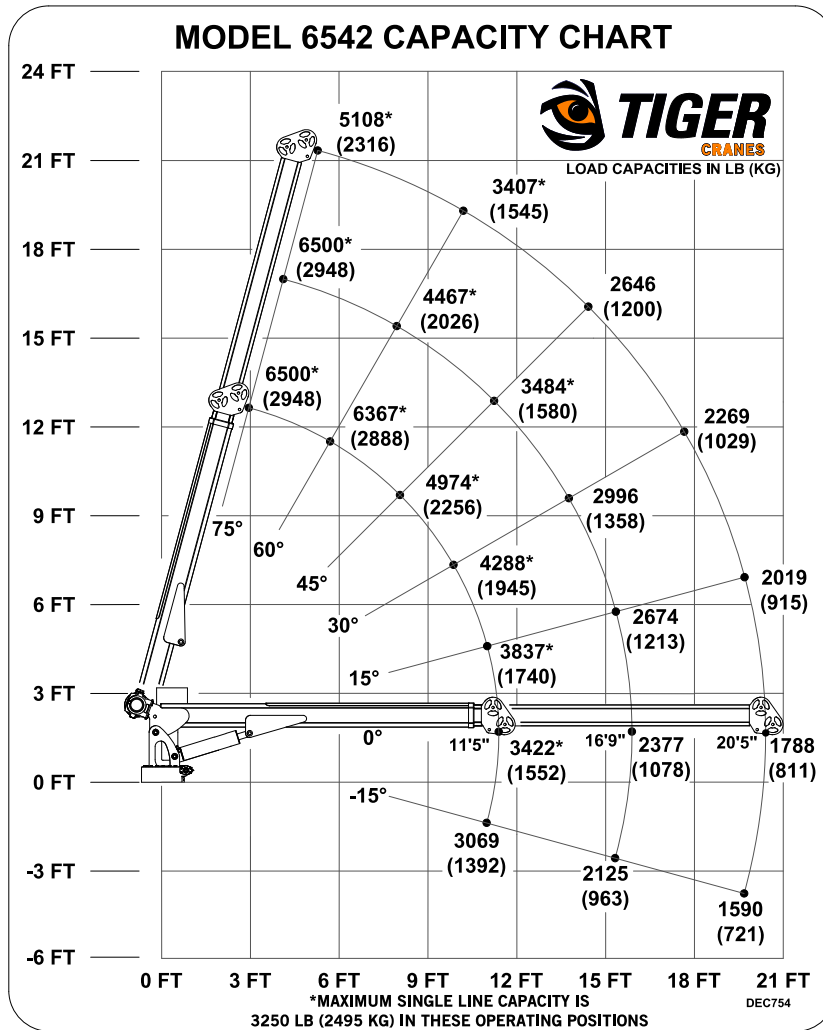

#### Bolt Hole Pattern

