



TIGER

CRANES

Model 1061 Specifications

Model 1061 Specifications

Dimensional Specifications:

- 21' Reach
- 12-21' Hydraulic Boom Extension
- 18.5' Lifting Height
- 42" Storage Height
- 158" Overall Storage Length
- Ø21" Mounting Space Required
- 8 Bolt Mounting Pattern
- 7/16" X 120' Winch Cable
- 2070 lbs. Operating Weight
- Ø40.8" Rotation Clearance Required

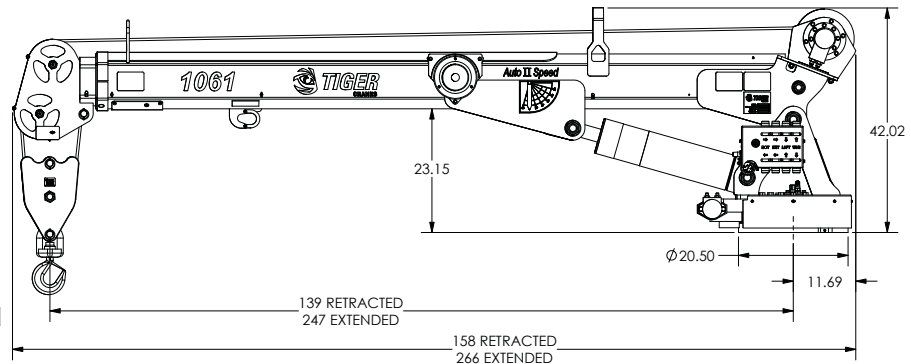

Performance Specifications:

- 66,000 ft-lb Crane Rating
- 72,200 ft-lb Maximum Crane Lifting Moment
- 11,000 lb Double Line Lift Capacity
- 22 second Boom Elevation Time
- 22 second Boom Extension Time
- 1.2 RPM Rotation Speed
- 60 FPM No Load Single Line Speed
- 400 Degrees of Rotation
- -6.5 Degrees to +82 Degrees Boom Angle

Standard Features:

- Wireless Control with 2 way remote to receiver communication, including 4 hydraulic functions with proportional trigger, horn button, engine start/stop switch and engine speed control and accessory switch. Requires 4 AA batteries.
- Load percentage indication with 4 character display on remote.
- Auto II Speed control reduces maximum speed on all functions when a load is sensed.
- 33' tether cable included for operation without batteries or in areas where radio transmission is not allowed.
- Anti two block & overload protection with condition indicators on remote.
- Sealed turret
- Integrated filtration with bypass condition indicator.
- 12 VDC DO3 10 GPM solenoids with manual overrides & LED On/Off indicator DIN connectors
- Hydraulic planetary winch. Boom mounted for easier stowing.
- Crane lift and extension cylinders are equipped with counterbalance safety valves.
- Powder coated base, turret shield and inner boom, with PPG Delfleet polyurethane paint on other components.
- This crane is designed to meet the requirements of ANSI/ASME B30.5 (2011) and OSHA 1910.180.

Minimum Requirements:

- 25,500 lbs. GVW Rating
- 84" Cab to Axle
- 900,000 in-lb frame RBM
- 10 GPM @ 2775 PSI – open center hydraulics
- 66,000 ft-lb rated crane tower reinforcement and outrigger



TIGER

CRANES

Model 1061 Specifications

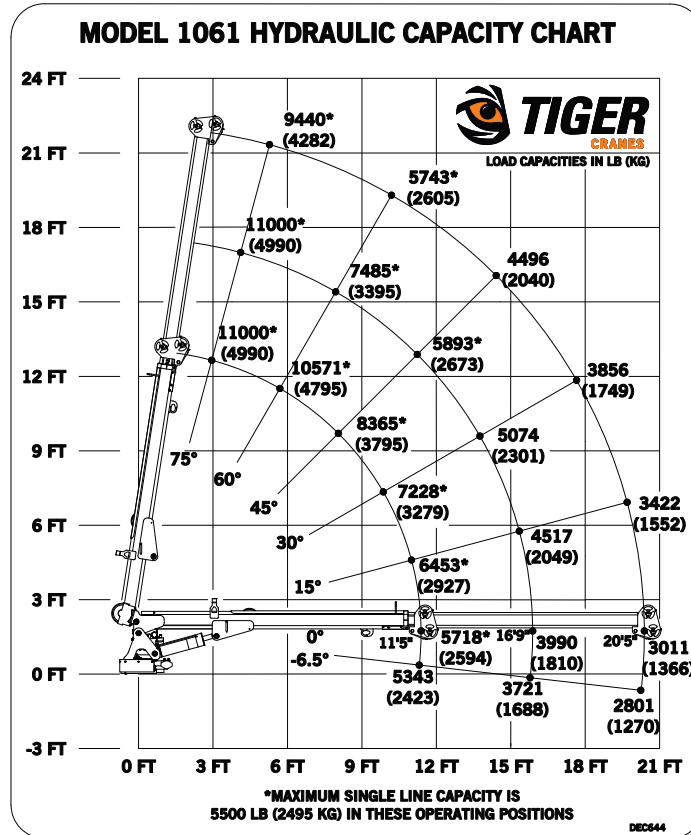

Bolt Hole Pattern

