



# TIGER

## CRANES

### Model 5032E Specifications

#### Model 5032E Specifications

##### Dimensional Specifications:

- 21' Reach
- 12-21' Hydraulic boom extension
- 18.5' Lifting height
- 38" Storage height
- 160" Overall storage length
- Ø18" Mounting space required
- 6 Bolt mounting pattern
- 3/8" X 120' Winch cable
- 1445 lbs. Operating weight
- Ø29" Rotation clearance required

##### Performance Specifications:

- 30,000 ft-lb Crane rating
- 32,975 ft-lb Maximum crane lifting moment
- 5,00 lb Double line lift capacity
- 400 Degrees of rotation
- -15 Degrees to +73 degrees boom angle
- Winch performance

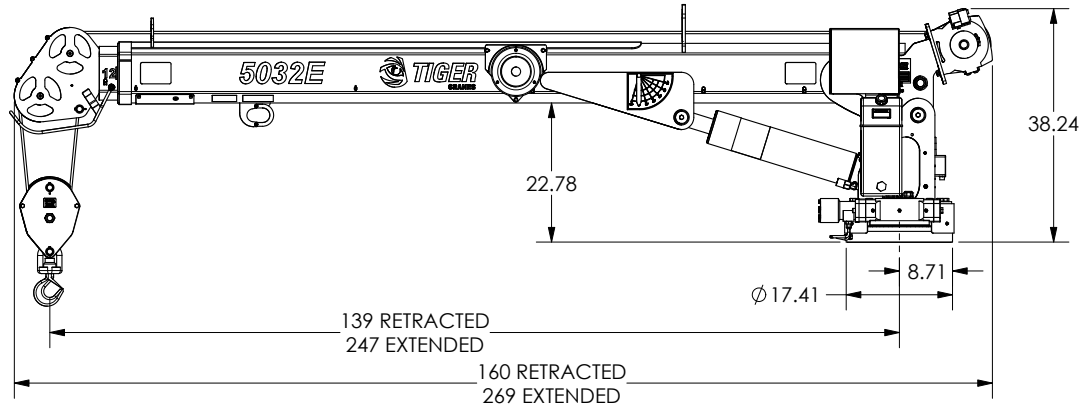

LOAD	PART LINE	LIFTING SPEED
0 lbs	1	36 FPM
3250 lbs	2	10 FPM

##### Standard Features:

- 2-way handheld wireless control with percentage of load display
- Low profile anti-two-block protection
- Overload protection
- 10 VDC cartridge valves with manual overrides
- Boom mounted electric planetary winch for easier stowing
- Stationary rotator gearcase
- Sealed crane turret
- Low profile jib head
- Hydraulic cylinders equipped with counterbalance safety valves
- PPG Delfleet polyurethane paint
- Designed to meet the requirements of ANSI/ASME B30.5 (2018) and OSHA 1910.180.

##### Optional Features:

- Self-leveling LED boom tip lights controlled by remote
- Tethered pistol grip remote with 25' cord and percentage of load display

##### Minimum Chassis/Power Requirements:

- 14,500 lbs. GVW rating
- 60" Cab to axle
- 300,000 in-lb frame RBM
- 30,000 ft-lb rated outrigger
- 90 Amp alternator
- 700 Cold cranking amp battery



# TIGER

## CRANES

### Model 5032E Specifications

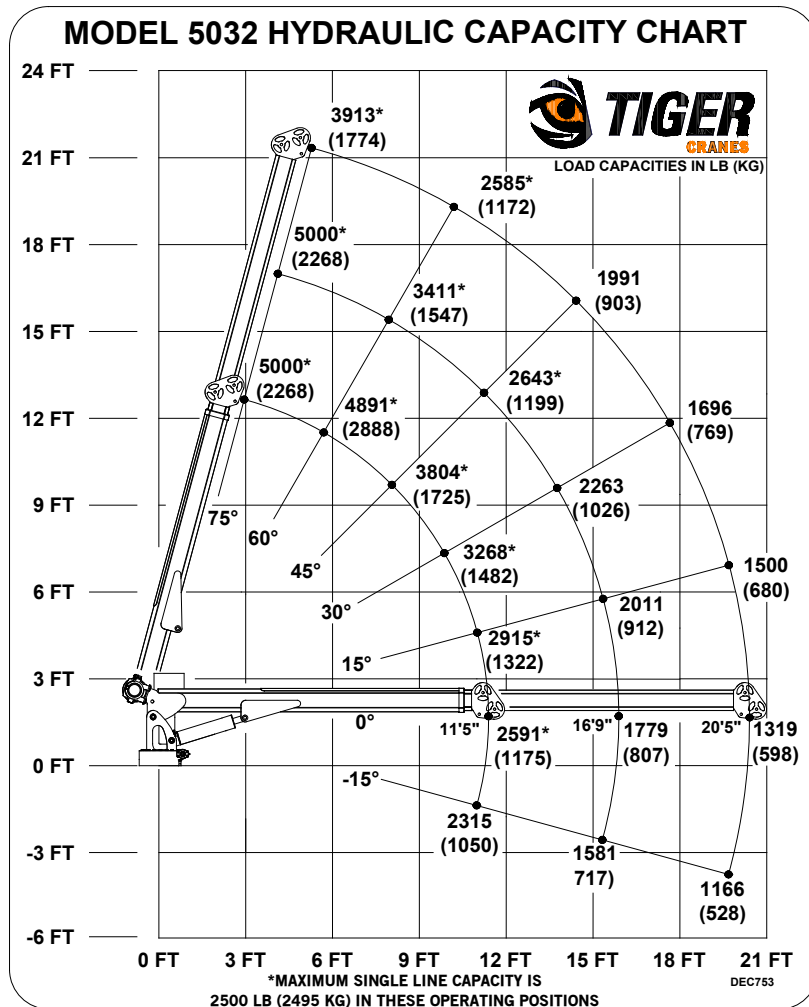

### Bolt Hole Pattern

