



# TIGER

## CRANES

### Model 6542EP Specifications

#### Model 6542EP Specifications

##### Dimensional Specifications:

- 21' Reach
- 12-21' Hydraulic boom extension
- 18.5' Lifting height
- 39" Storage height
- 161" Overall storage length
- Ø18" Mounting space required
- 6 Bolt mounting pattern
- 3/8" X 120' Winch cable
- 1500 lbs. Operating weight
- Ø29" Rotation clearance required

##### Performance Specifications:

- 40,000 ft-lb crane rating
- 43,200 ft-lb maximum crane lifting
- 6,500 lb double line lift capacity
- 400 degrees of rotation
- -15 degrees to +73 degrees Boom Angle
- Winch performance

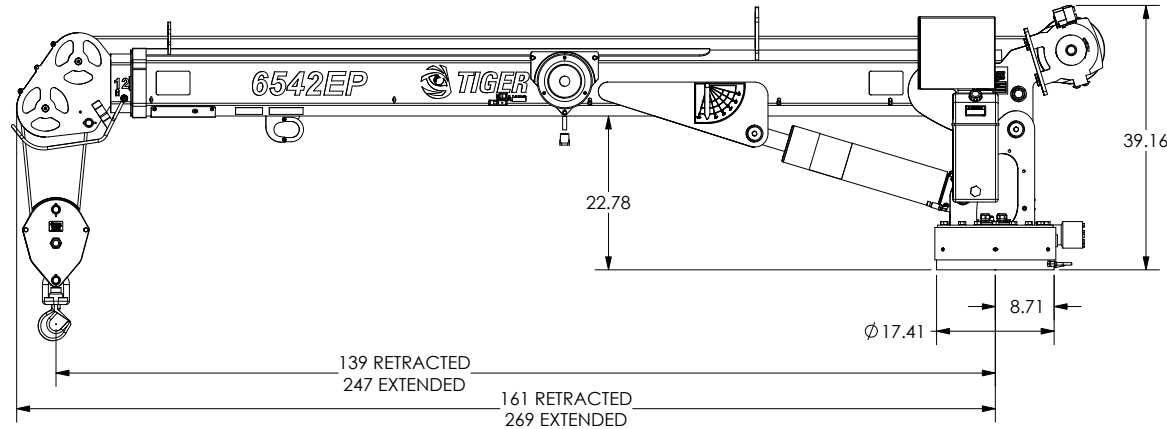

LOAD	PART LINE	LIFTING SPEED
0 lbs	1	36 FPM
3250 lbs	2	10 FPM

##### Standard Features:

- 2-way proportional wireless pistol grip control, Including 3 hydraulic functions with proportional trigger, 1 on/off winch function with trigger interlock, engine start/stop switch and engine speed control and accessory switch.
- Load percentage indication with 4 character display on remote
- 33' tether cable included for operation without batteries or in areas where radio transmission is not allowed
- Low profile anti-two-block protection
- Overload protection
- 10 VDC cartridge valves with manual overrides
- Boom mounted electric planetary winch for easier stowing
- Stationary rotator gearcase
- Sealed crane turret
- Low profile jib head
- Hydraulic cylinders equipped with counterbalance safety valves
- PPG Delfleet polyurethane paint
- Designed to meet the requirements of ANSI/ASME B30.5 (2018) and OSHA 1910.180.

##### Optional Features:

- Self-leveling LED boom tip lights controlled by remote

##### Minimum Chassis/Power Requirements:

- 14,500 lbs. GVW rating
- 60" Cab to axle
- 300,000 in-lb Frame RBM
- 40,000 ft-lb rated outrigger
- 90 Amp alternator
- 700 Cold cranking amp battery



# TIGER

## CRANES

### Model 6542EP Specifications

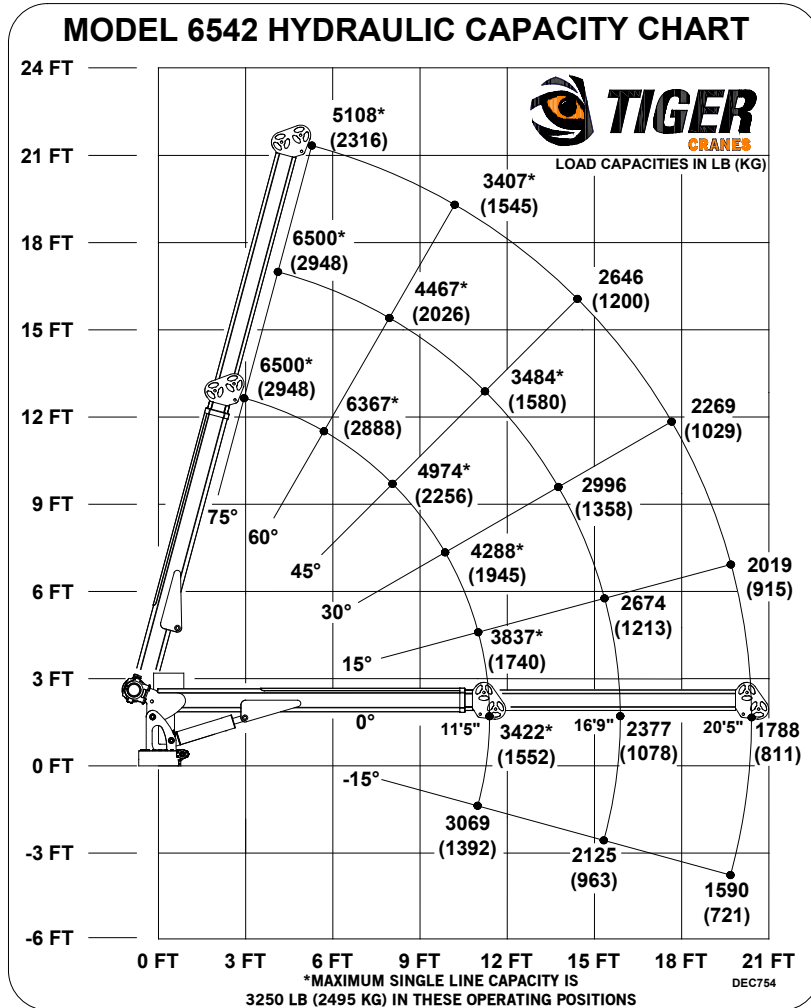

#### Bolt Hole Pattern

