



TIGER

CRANES

Model 3216EP Specifications

Model 3216EP Specifications

Dimensional Specifications:

- 16.5' Reach
- 7'8"-11'10" Hydraulic Boom Extension
- 11'10"-16'6" Manual Boom Extension
- 15' Lifting Height (from base of crane)
- 32" Storage Height (from base of crane)
- 108" Overall Storage Length
- 14"X14" Mounting Space Required
- 8" Square Bolt Mounting Pattern
- 1/4" X 80' Aircraft Winch Cable
- 750 lbs. Operating Weight

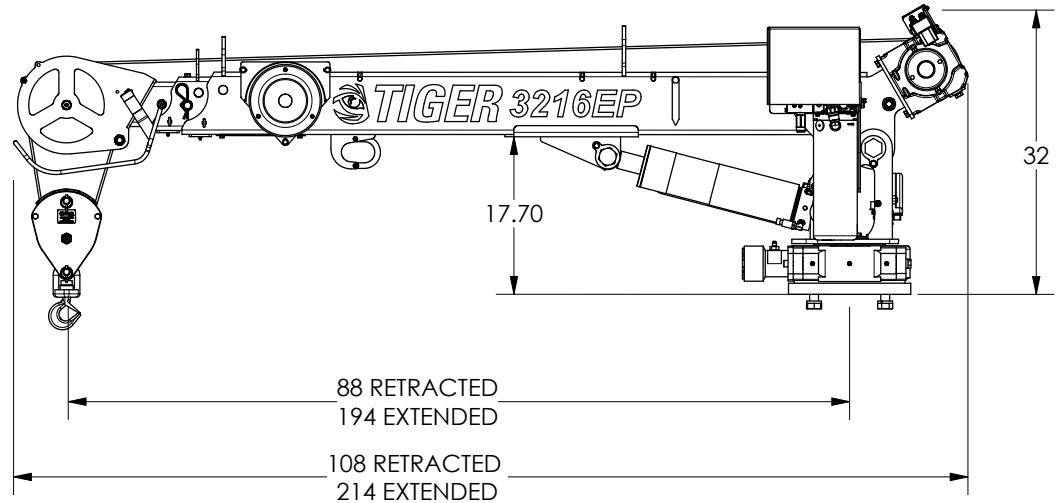

Performance Specifications:

- 12,500 ft-lb Crane Rating
- 13,800 ft-lb Maximum Crane Lifting Moment
- 3200 lb Double Line Lift Capacity
- 400 Degrees of Rotation
- -10 Degrees to +75 Degrees Boom Angle
- Winch Performance

LOAD	LIFTING SPEED
0 lbs	22 FPM
500 lbs	18FPM
750 lbs	18FPM

Standard Features:

- Wireless pistol grip control with high resolution LCD display for load percentage and diagnostics. Dual joysticks for selecting hydraulic/electric functions with proportional control trigger. Also includes horn, boom lights, compressor, engine start/stop, engine speed control, and 2 auxiliary switches.
- 33' tether cable included for operation without batteries or in areas where radio transmission is not allowed
- 10 VDC Cartridge Valves with manual overrides
- Electric planetary winch - Boom mounted for easy stowing.
- Sealed turret
- Crane lift cylinder is equipped with a counterbalance safety valve & overload protection.
- Low profile jib head and anti two block mechanism.
- This crane is designed to meet the requirements of ANSI/ASME B30.5 (2011) and OSHA 1910.180.

Minimum Chassis/Power Requirements:

- 11,000 lbs. GVW Rating
- 60" Cab to Axle
- 12,500 ft-lb Rated crane tower reinforcement and outrigger
- 90 Amp Alternator



TIGER

CRANES

Model 3216EP Specifications

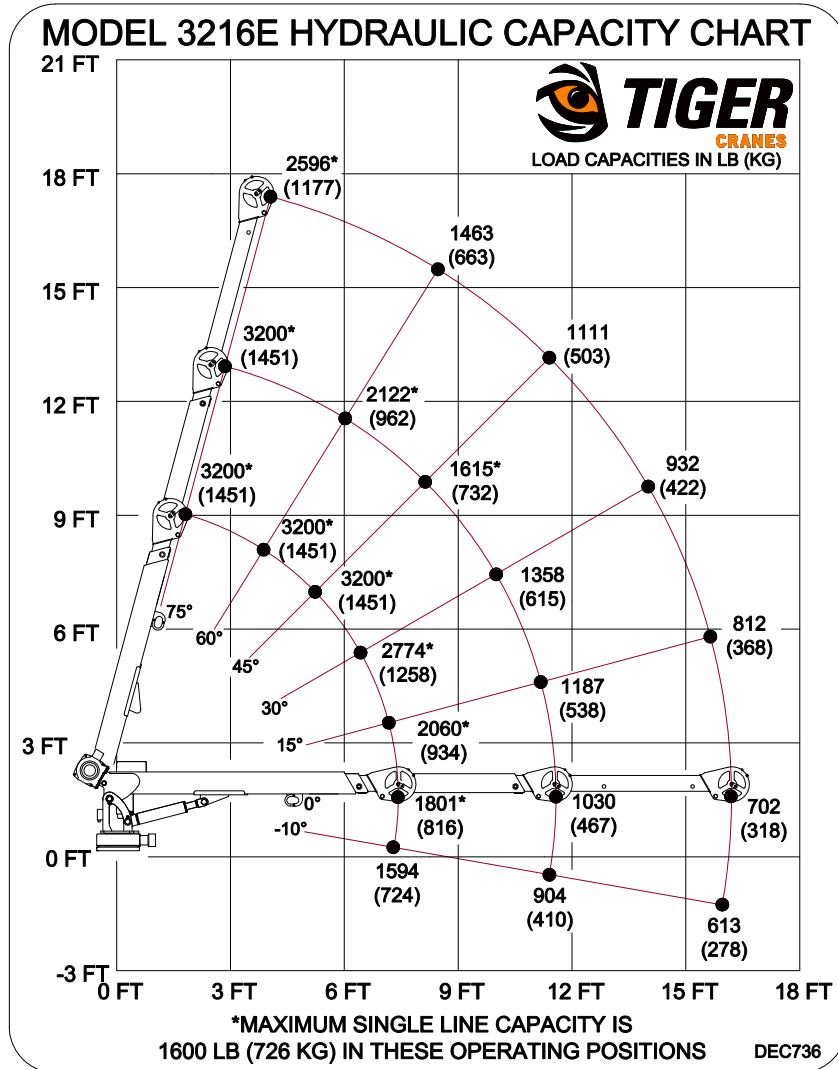

Bolt Hole Pattern

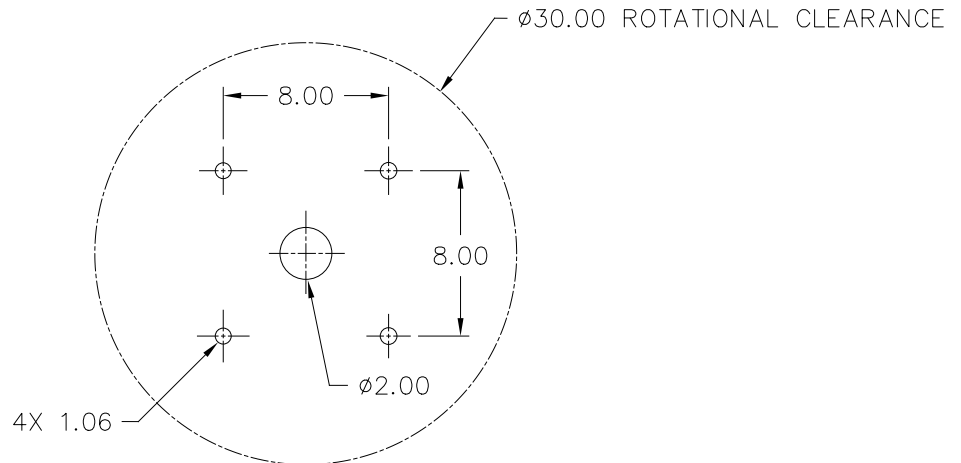

3216E/4016E MOUNTING PATTERN