

## SERIES I - 2244 9ft Crane Body

### Body Materials

- 12 ga and 14 ga A60 galvaneal cabinet panels
- 11 ga A60 galvaneal single panel doors
- 3" structural C channel long sills run full length
- 12 ga 2x4 formed C channel cross rails on 11" centers
- 14 ga A60 galvaneal treadplate deck floor
- 11ga workbench top

### Body Dimensions

- 96" Max Cabinet width, 98.5" Overall Body Width @ drip rails
- 22.5" Overall cabinet depth with 21.4" inside depth clearance
- 44" Overall cabinet height
- 51" x 108" Deck Area
- 25" Deck Side Height
- 8" treadplate step
- 18 3/4" workbench with full through cabinet w/ integrated vise mount

### Standard Features

- Body, crane tower, and outriggers rated at 30,000 ft-lbs moment load
- 102 Cubic feet of storage capacity
- Stainless Steel wrap around chip guard full height on front of cabinets
- Full length rain gutter
- Galvanized infinitely adjustable shelving ( 6 shelf kit ) 250 lb capacity
- High performance cabinet pressurization system with filtered air
- Fully sealed crane tower also functions as a storage cabinet
- 3 point locking door system features blind mounted door handles for security
- Polished stainless steel door handles feature compression latching, paddle lockable
- (4) Flush mounted cargo tie downs
- Stainless Steel grab handles for rear egress
- Stainless Steel spring loaded door checks
- Spring loaded crane saddle w/ stow guage
- Body mounted back-up alarm
- Automotive bulb, steelbacked weather stripping between doors and cabinets
- Plug and Play harnessing
- Body is fully sanded, chemically washed and prepped prior to paint
- 3 step Paint Process with PPG Delfleet Polyurethane topcoat - exterior and interior
- Body is fully undercoated
- LED Lights and reflectors are mounted per DOT specifications
- 2 1/2" Class V receiver hitch rated @ 1,800 lbs tongue weight and 18,000 lbs Gross Trailer Weight
- Standard mounting points for air compressor and welder
- Manual extend/Manual crank down Outrigger
- Internal Hinge Design to minimize corrosion
- Manual Holder for all manuals included with unit
- Mud Flaps

### Options

- Rollout Drawers and Bolt bins
- Welders
- Cabinet Strip Lighting
- Bedliner
- Deck Covers
- Lube Kits
- Gas Compressors
- Fold Down Step/Hand Rail
- Oxy/Acetylene mounting brackets w/ vent
- LED Interior/ Exterior Lighting in designated areas
- SS Jamb Covers
- Backup Camera,
- Bench Vise
- Inverters
- All in one Compressor/Welder System
- Extra Shelving
- Keylock Cylinder Covers
- Tailgate
- Trailer Plug
- (Front of bed) Headgate

### Flat Top Cabinets

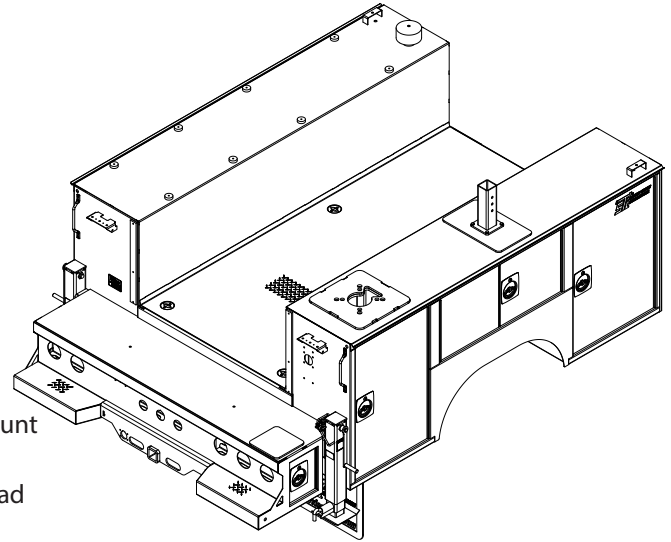

# SERIES I - 2244 9ft Crane Body Dimensions

