

SERIES I - 2250 11ft Crane Body

Body Materials

- 12 ga A60 galvalneal tops, backs and bottom and 14 ga end panels on cabinets with stitch weld construction
- 11 ga A60 galvalneal single panel doors
- 3" structural C channel long sills run full length
- 12 ga 2x4 formed C channel cross rails on 12" centers
- 11 ga A60 galvalneal treadplate deck floor
- 3/16" workbench top with clamping lip

Body Dimensions

- 96" Max Cabinet width, 98.5" Overall Body Width @ drip rails
- 22.5" Overall cabinet depth with 21.4" inside depth clearance
- 50" Overall cabinet height
- 60" Raised Oxygen Acetylene cabinet
- 51" x 132" Deck Area
- 31" Deck Side Height
- 22" Workbench with full through cabinet w/ integrated vise mount
- 8.5" Treadplate step

Standard Features

- Body, crane tower, and outriggers rated at 53,000 ft-lbs moment load
- 146 Cubic feet of storage capacity
- Stainless Steel wrap around chip guard full height on front of cabinets
- Full length rain gutter
- Galvanized infinitely adjustable shelving (7 shelf kit) 250 lb capacity
- High Performance cabinet pressurization system with filtered air
- Oxy/Act cabinet is vented, and includes tank brackets for K bottles
- Fully sealed crane tower also functions as a storage cabinet
- 3 point locking door system features blind mounted door handles for security
- Polished stainless steel door handles feature compression latching, paddle lockable
- (6) Flush mounted cargo tie downs
- Stainless Steel grab handles for rear egress
- Stainless Steel spring loaded door checks
- Spring loaded crane saddle w/ stow guage
- Body mounted back-up alarm
- Automotive bulb, steelbacked weather stripping between doors and cabinets
- Plug and Play harnessing
- Logic based electrical system with central fuse and breaker hub
- Body is fully sanded, chemically washed and prepped prior to paint
- 3 step Paint Process with PPG Delfleet Polyurethane topcoat - exterior and interior
- Body is fully undercoated
- LED Lights and reflectors are mounted per DOT specifications
- 2 1/2" Class V receiver hitch rated @ 1,800 lbs tongue weight and 18,000 lbs Gross Trailer Weight
- Standard mounting points for air compressor and welder
- Internal Hinge Design
- Manual Holder for all manuals included with the unit
- Mud Flaps

Options

- Rollout Drawers and Bolt bins
- Welders
- LED Interior/ Exterior Lighting in designated areas
- Cabinet Strip Lighting
- Bedliner
- Deck Covers
- Lube Kits
- Gas and Hydraulic Compressors
- All in One Power Systems
- Fold Down Step/Hand Rail
- Masterlock - SS Jamb Covers
- Backup Camera,
- Bench Vise
- Inverters
- Extra Shelving
- Keylock Cylinder Covers
- Tailgate
- Trailer Plug
- (Front of bed) Headgate
- Manual or Hydraulic Outriggers (hydraulic hoses installed internally to eliminate exposure on hydraulic outriggers)

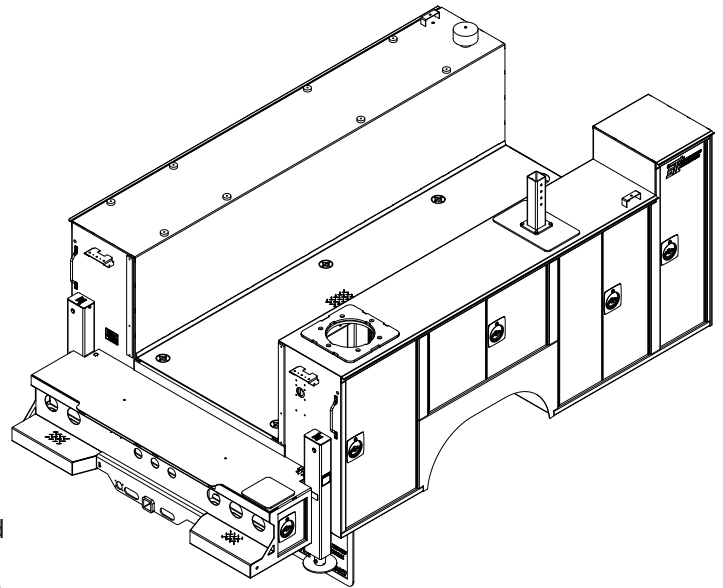

SERIES I - 2250 11ft Crane Body Dimensions

