

SERIES II - 2460 14ft Crane Body

Body Materials

- 12 ga A60 galvaneal top and back cabinet panels with 11 ga bottoms utilizing continuous weld construction
- 11 ga A60 galvaneal single panel doors
- 11 ga rigidized A60 galvaneal deck plate and bumper
- Rigidized A60 galvaneal cabinet overlay
- 1/4" x 2" x 3" structural tube long sills run full length
- 10 ga 2x4 formed C channel cross rails on 12" centers
- 1/4" Workbench top

Body Dimensions

- 99" Max Cabinet Width, 101.5" Overall Body Width @ drip rails
- 24" Overall cabinet depth with 22.5" inside depth clearance
- 60" Overall cabinet height
- 60" Vented Oxygen Acetylene cabinet
- 51" x 171" Deck Area
- 35" Deck Side Height
- 8.5" Step Treadplate Bumper
- 25" Workbench with finished full through cabinet w/ integrated vise mount

Standard Features

- Body, crane tower, and outriggers rated at 90,000 ft-lbs moment load
- 254 Cubic feet of storage capacity
- Stainless Steel wrap around chip guard full height on front of cabinets
- Full length rain gutter
- Galvanized infinitely adjustable shelving - 250 lb capacity
- 11 Shelf kit
- High Performance cabinet pressurization system with filtered air
- Oxy/Act cabinet is vented, and includes tank brackets for K bottles
- Fully sealed crane tower also functions as a storage cabinet
- 3 point locking door system features blind mounted door handles for security
- Polished stainless steel door handles feature compression latching, paddle lockable
- Outrigger hoses installed internally to eliminate exposure
- (8) Flush mounted cargo tie downs - 3500 lb capacity
- Stainless Steel grab handles for rear egress
- Stainless Steel spring loaded door checks
- Spring loaded crane saddle w/ stow guage
- Body mounted back-up alarm
- Automotive bulb, steelbacked weather stripping between doors and cabinets
- All wiring is protected in automotive loom
- Logic based electrical system with central fuse and breaker hub
- Body is fully sanded, chemically washed and prepped prior to paint
- 3 step Paint Process with PPG Delfleet Polyurethane topcoat - exterior and interior
- Body is fully undercoated
- LED Lights and reflectors are mounted per DOT specifications
- 2 1/2" Class V receiver hitch rated @ 1,800 lbs tongue weight and 18,000 lbs Gross Trailer Weight
- Standard mounting points for air compressor and welder
- Internal Hinge Design
- Hydraulic Reservoir
- Manual Holder for all manuals included with the unit
- Mud Flaps

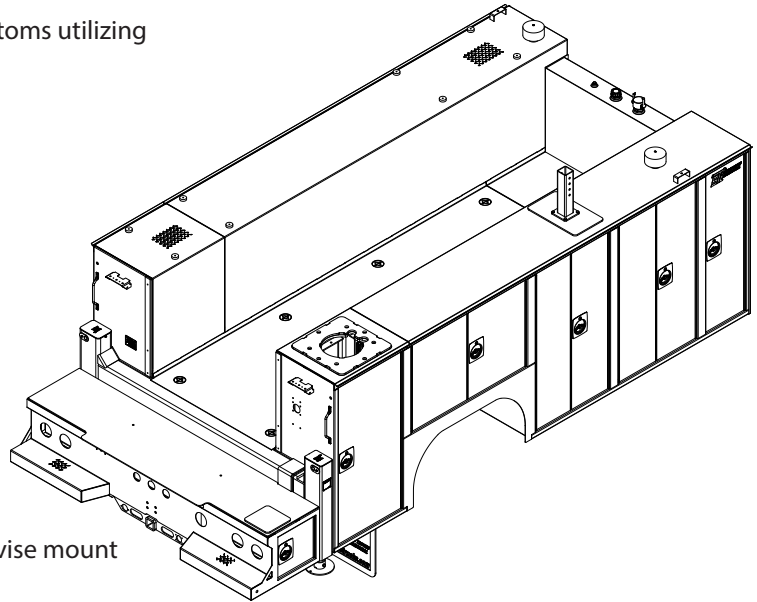

Options

- Rollout Drawers and Bolt bins
- LED Interior/Exterior Lighting in designated areas
- Bedliner
- Deck Covers
- Gas and Hydraulic Compressors
- Lube Kits
- Pintle hitch
- Welders
- Bedliner
- Cabinet Strip Lighting
- Gas and Hydraulic Compressors
- All in One Power Systems
- Fold Down Step/Hand Rail
- Masterlock
- Bench Vise
- Backup Camera,
- Inverters
- Extra Shelving
- Keylock Cylinder Covers
- Tailgate
- Trailer Plug

SERIES II - 2460 14ft Crane Body Dimensions

