



TIGER CRANES

Model 6542E Specifications

Model 6542E Specifications

Dimensional Specifications:

- 21' Reach
- 12-21' Hydraulic boom extension
- 18.5' Lifting height
- 39" Storage height
- 161" Overall storage length
- Ø18" Mounting space required
- 6 Bolt mounting pattern
- 3/8" X 120' Hoist cable
- 1500 lbs. Operating weight
- Ø29" Rotation clearance required

Performance Specifications:

- 40,000 ft-lb crane rating
- 43,200 ft-lb maximum crane lifting moment
- 6,500 lb double line lift capacity
- 400 degrees of rotation
- -15 degrees to +73 degrees Boom Angle
- Hoist performance

LINE LOAD	LINE SPEED
0 lbs	23 FPM
1200 lbs	19 FPM
2400 lbs	17 FPM
3250 lbs	15 FPM

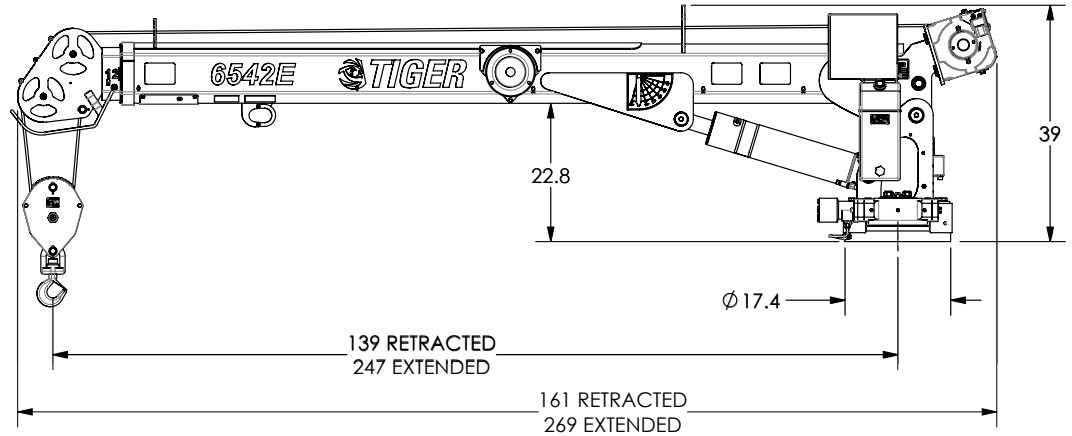

Standard Features:

- 2-way handheld wireless control with percentage of load display
- Low profile anti-two-block protection
- Overload protection
- 10 VDC cartridge valves with manual overrides
- Boom mounted electric planetary hoist for easier stowing
- Stationary rotator gearcase
- Sealed crane turret
- Low profile jib head
- Hydraulic cylinders equipped with counterbalance safety valves
- PPG Delfleet polyurethane paint
- Designed to meet the requirements of ANSI/ASME B30.5 (2018) and OSHA 1910.180.

Optional Features:

- Self-leveling LED boom tip lights controlled by remote
- Tethered pistol grip remote with 25' cord and percentage of load display

Minimum Chassis/Power Requirements:

- 14,500 lbs. GVW rating
- 84" Cab to axle
- 300,000 in-lb Frame RBM
- 40,000 ft-lb rated outrigger
- 200 Amp alternator
- 700 Cold cranking amp battery



TIGER

CRANES

Model 6542E Specifications

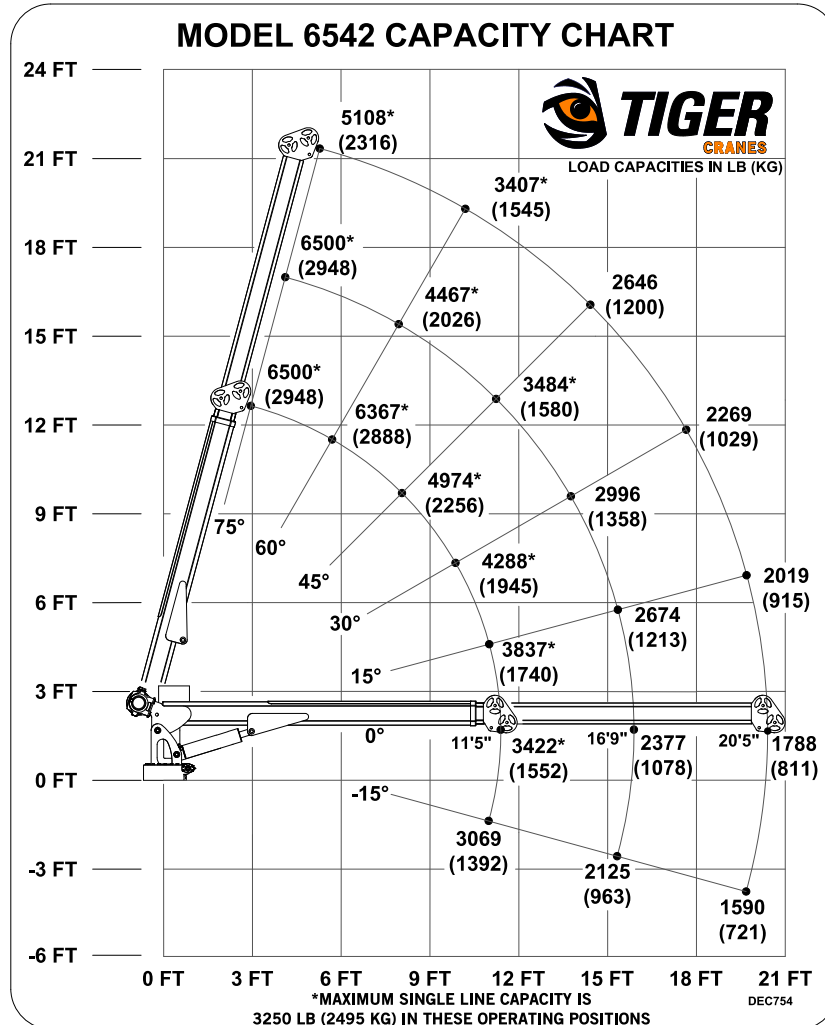

Bolt Hole Pattern

